

**BRAINF\*\*\***

is also a programming language :-)

# Channelmania!

Future-proof your DWDM network topology  
while keeping it flexible for 1.6T



**FLEXOPTIX**

**Digital Signal Processor**

**TRANSMITTER**

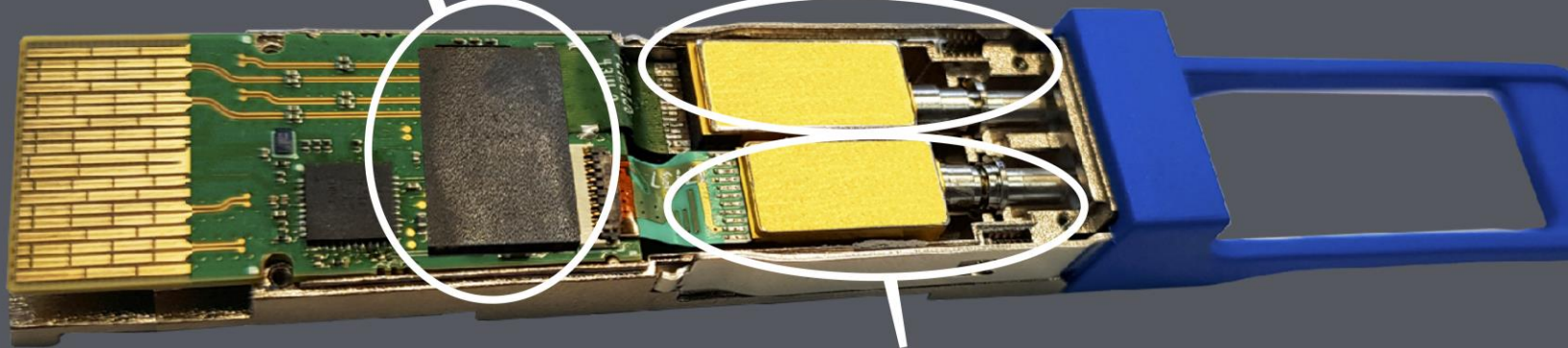

**reCEIVER**

Source / Laser

**Bulky  
Powerhungry  
Difficult to operate**

Past

Present

**Small  
Efficient  
Reliable**

1958: theoretical foundations for LASER  
1960: first ruby LASER  
1961: first HeNe LASER  
1962: first semiconductor LASER

1970: first semiconductor LASER  
@roomtemp.  
late 1970s: semiconductor LASER  
lifetime >1 Mio. HRS



# Source Spectrum

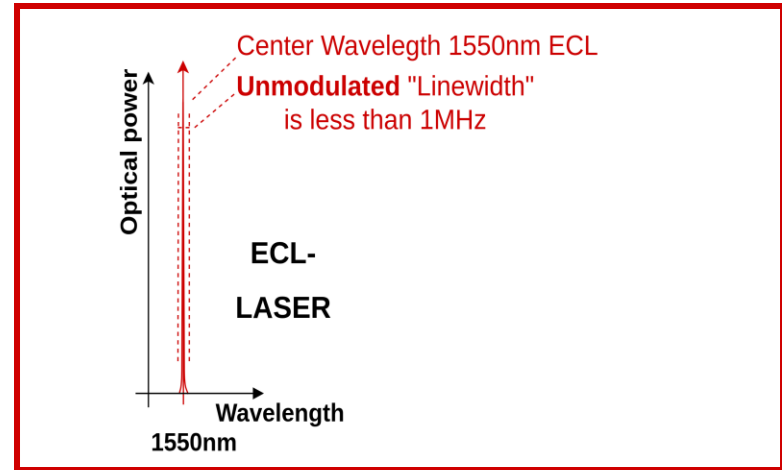
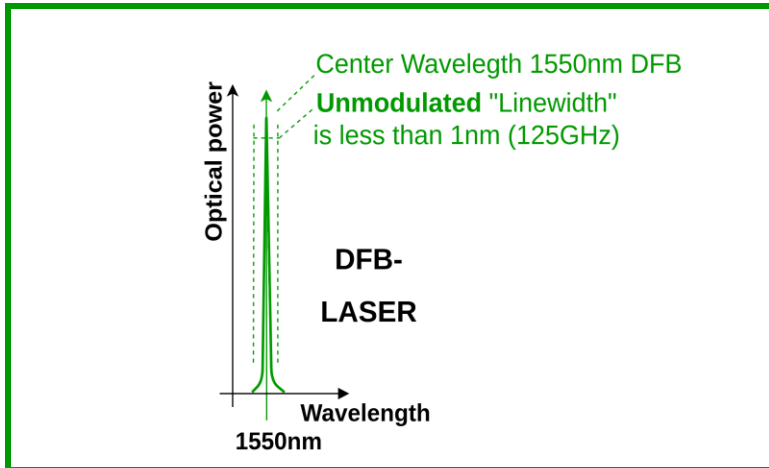
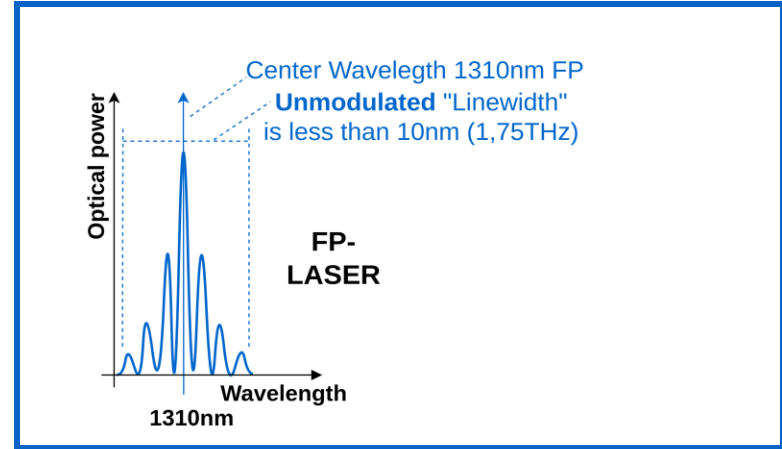
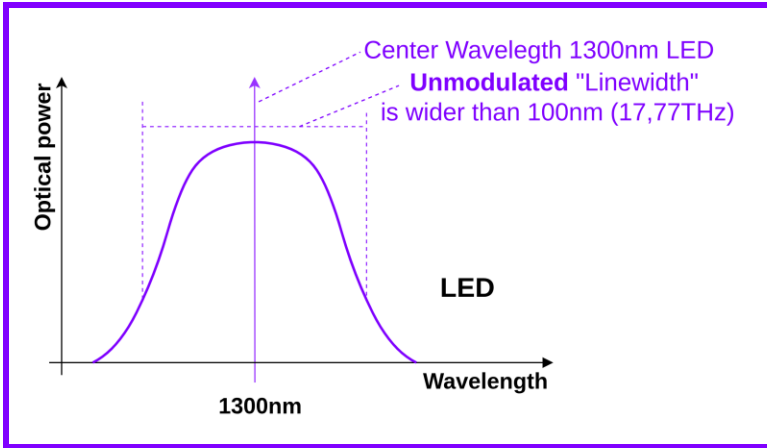

# Increasing bandwidth per fiber

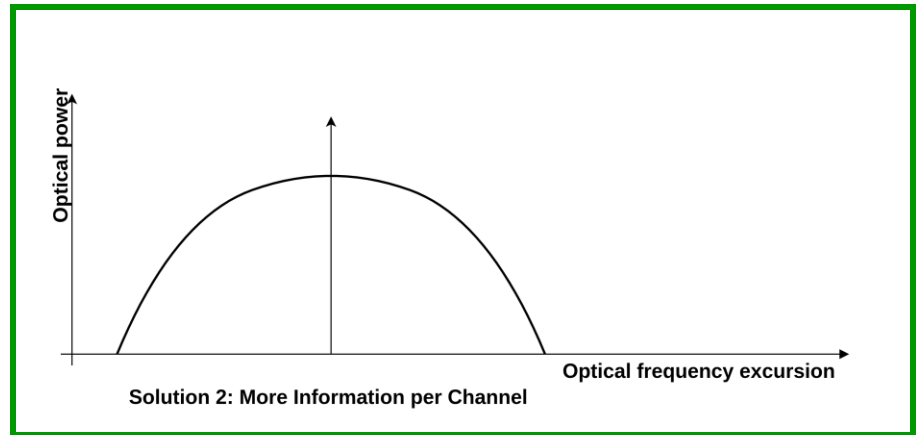
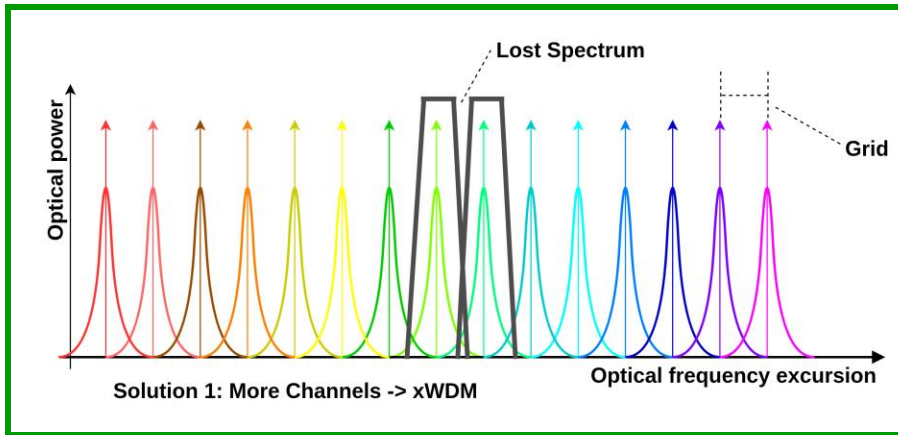
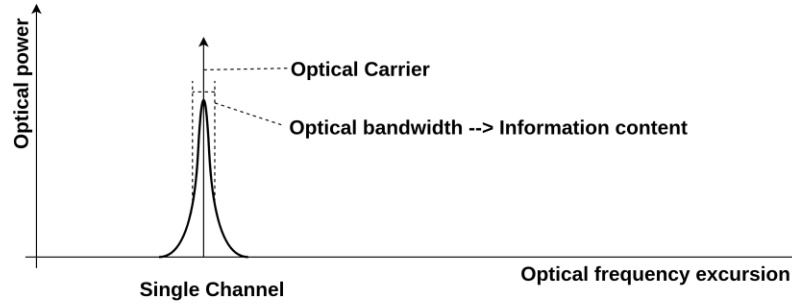

# this was the easy part 1/3

now back to complex numbers ->

# Limitations of On-Off-Keying (OOK) with Direct Detection

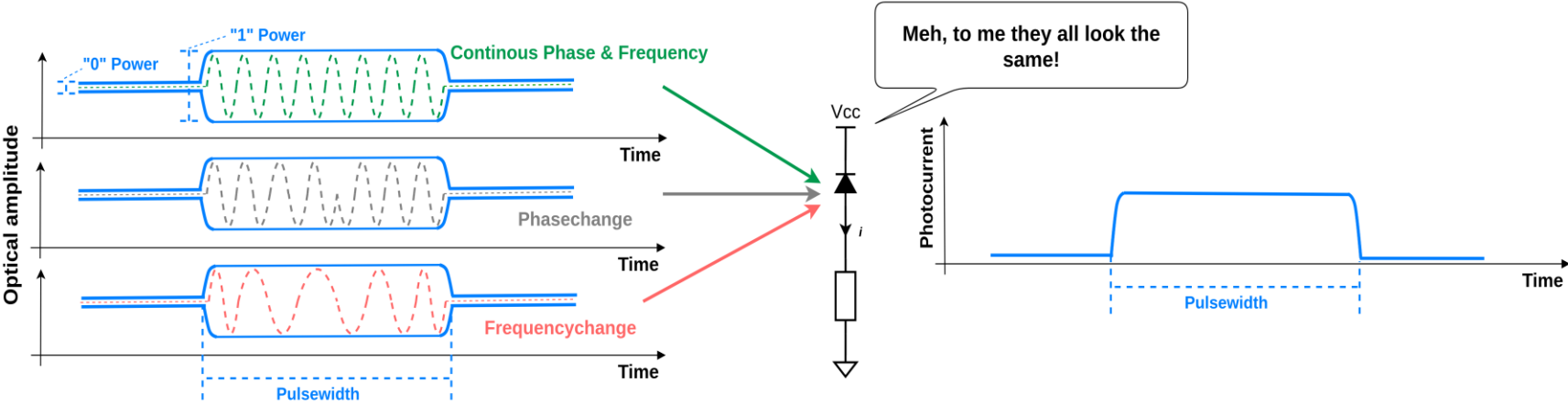

to be precise

The text "to be precise" is followed by three circuit symbols: a photodiode symbol with a small arrow pointing to the cathode, an equals sign ( $=$ ), and another photodiode symbol.

# Higher order modulation constellations

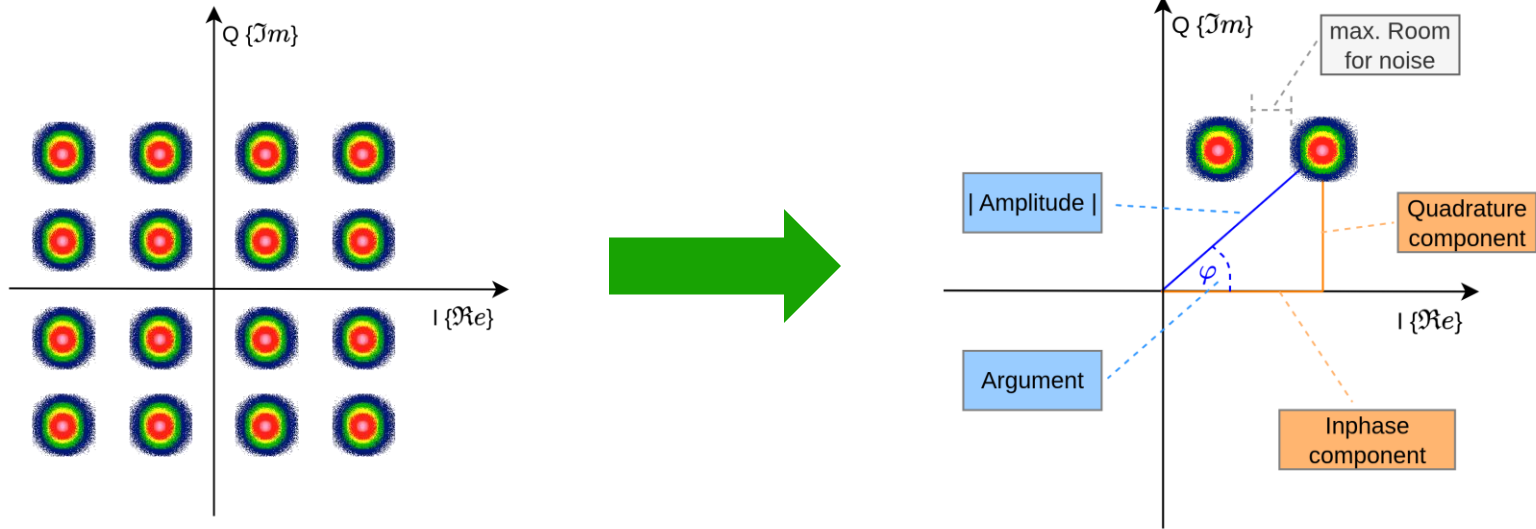

- 16 constellations encode 4 Bits/SYM
- Two of those patterns are sent on orthogonal polarizations
- 425Gbps @ 53.125GBd/s
- Constellation can be expressed by either **Amplitude and Argument** or by the **I and Q -components**
- Less room for noise, compared to OOK

# Receiver

Single-Ended

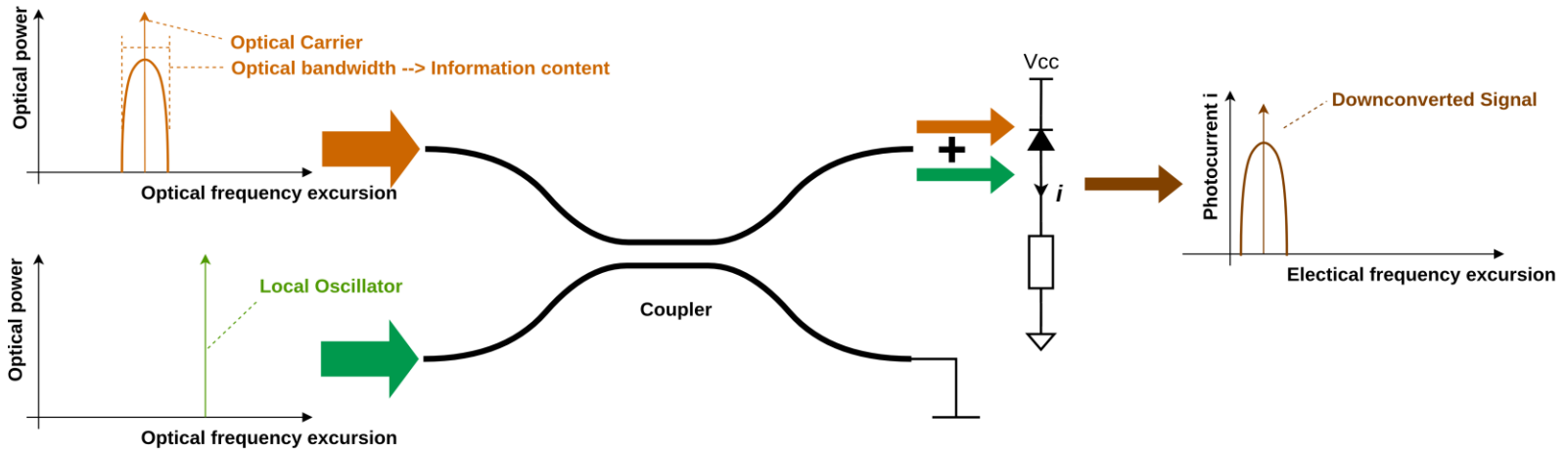

Balanced

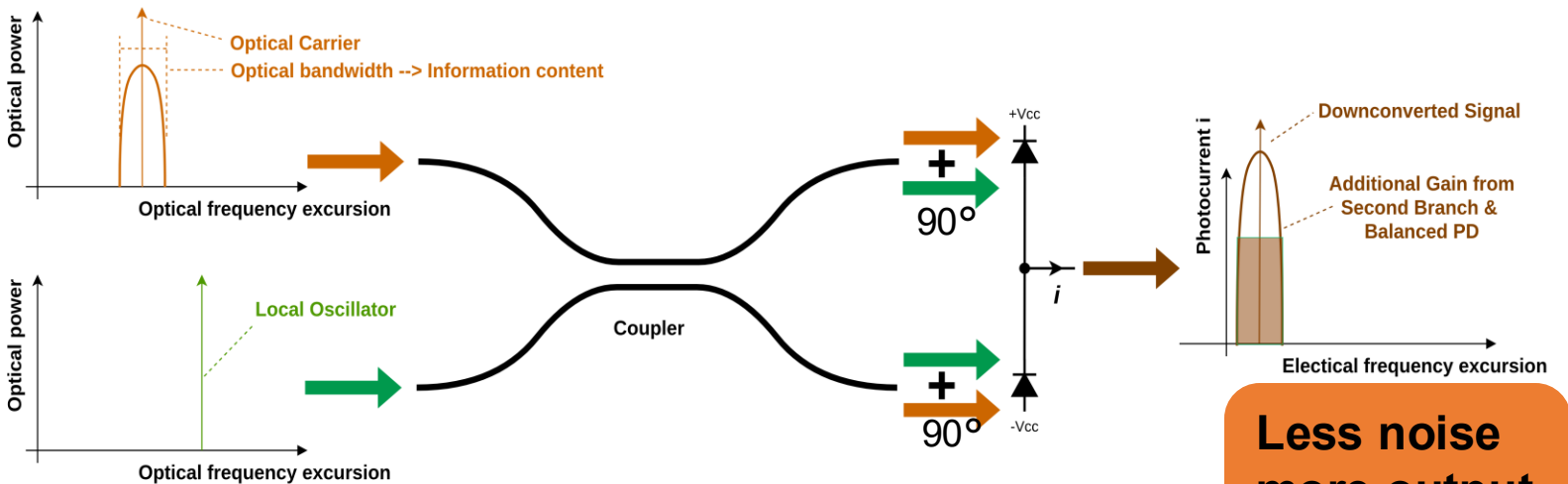

Less noise  
more output

# Phase-Diversity

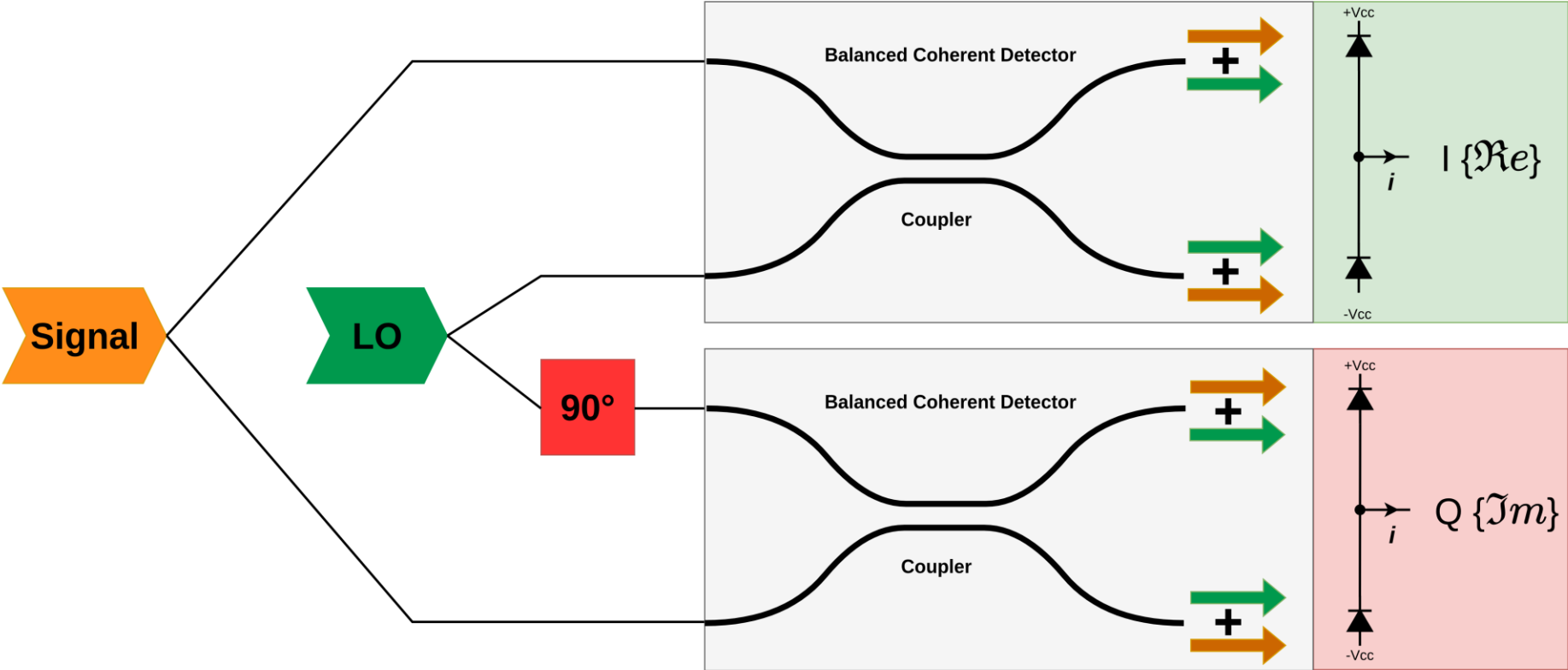

# Phase-&Polarization-Diversity

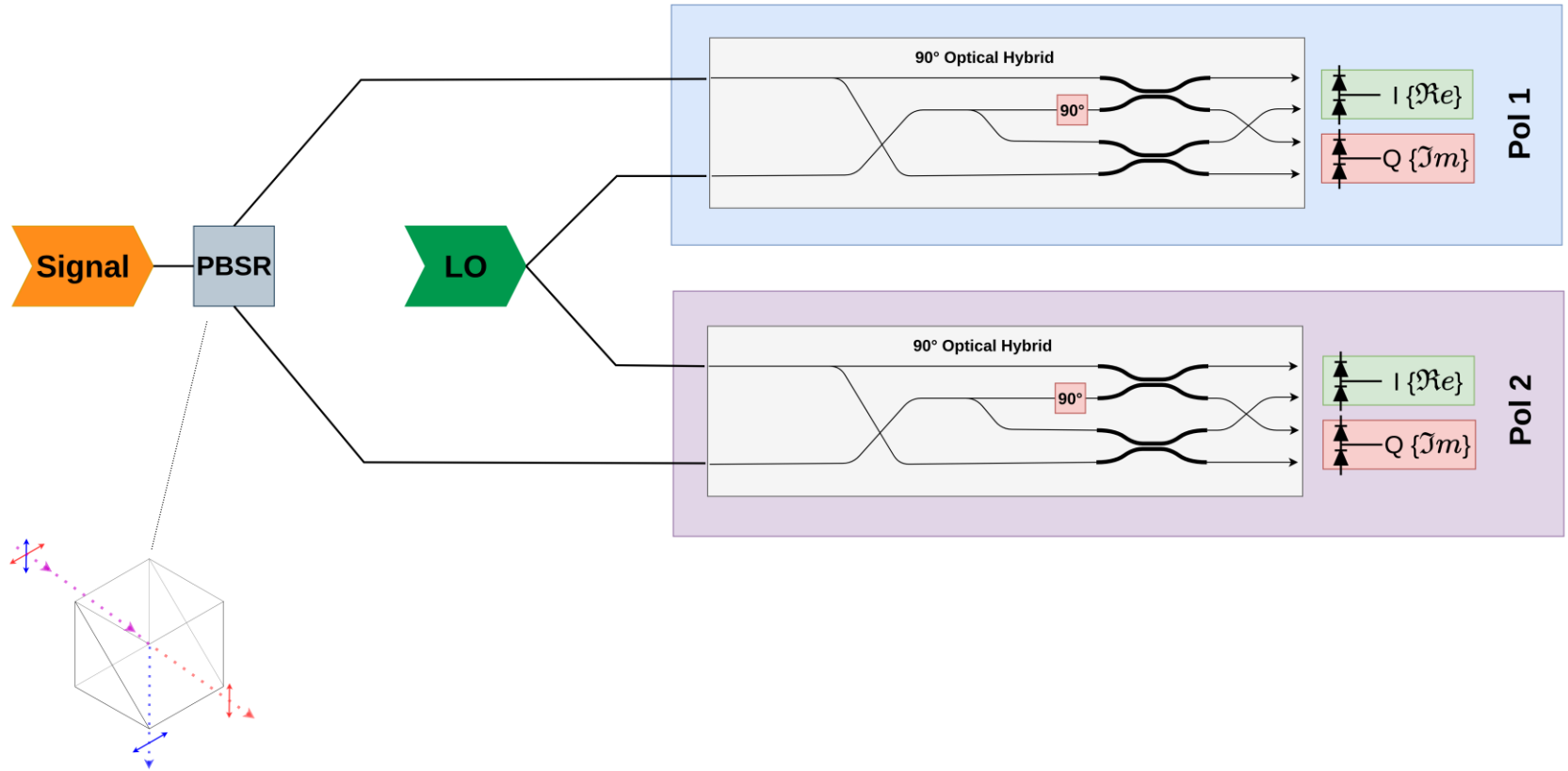

Don't tell me the sky's the limit when there are footprints on the moon.

Paul Brandt

DENOG17

10.11.2025  
Haus der  
Technik  
Essen  
Germany

# half way through

2/3

# Coherent Detection Bandwidth

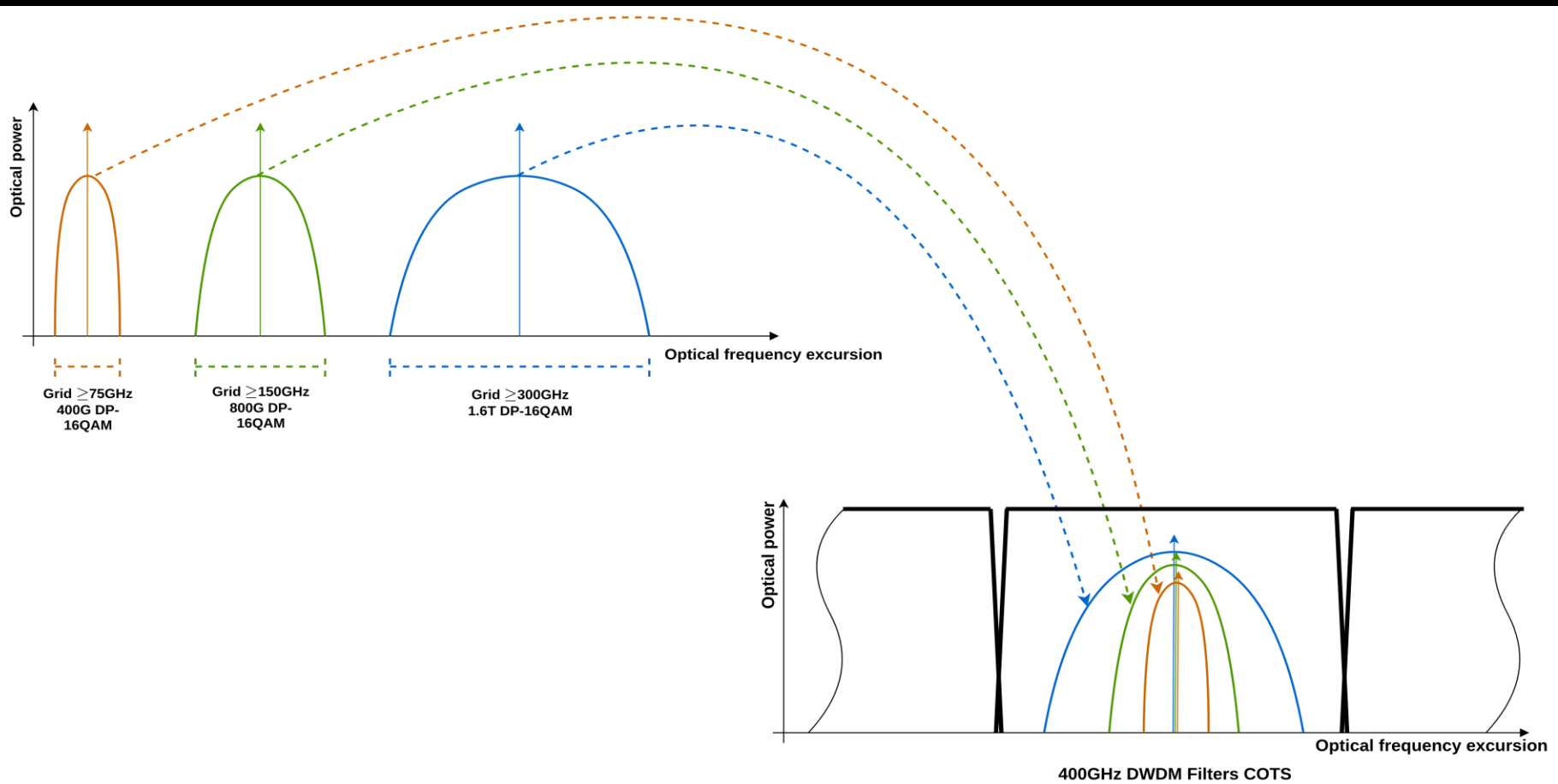

# 12 x 400GHz channels in C-Band

96 x 50GHz channels in C-Band

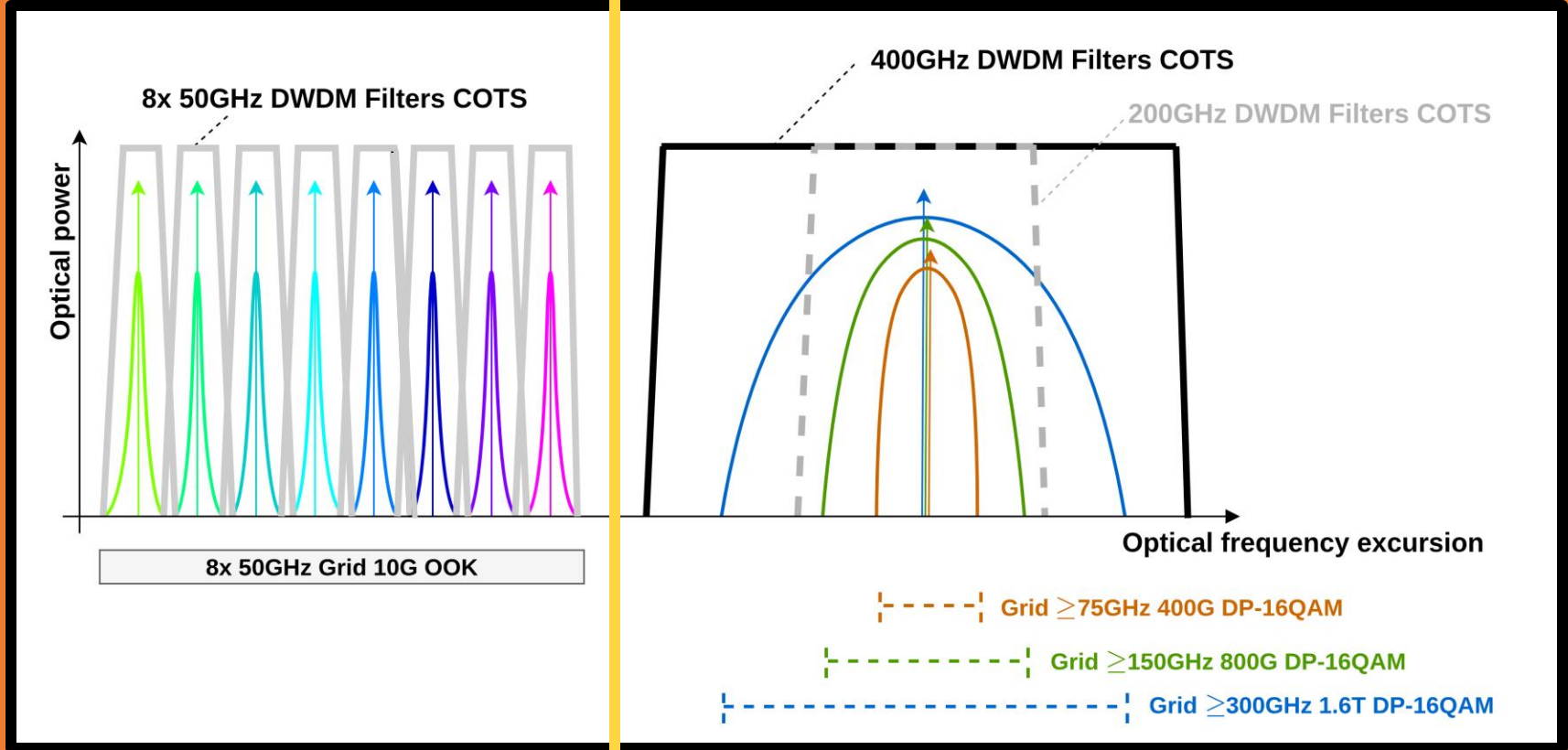

IL ~ 2dB

COTS = Commercial Off-The-Shelf

# downconverted signal

Heterodyne

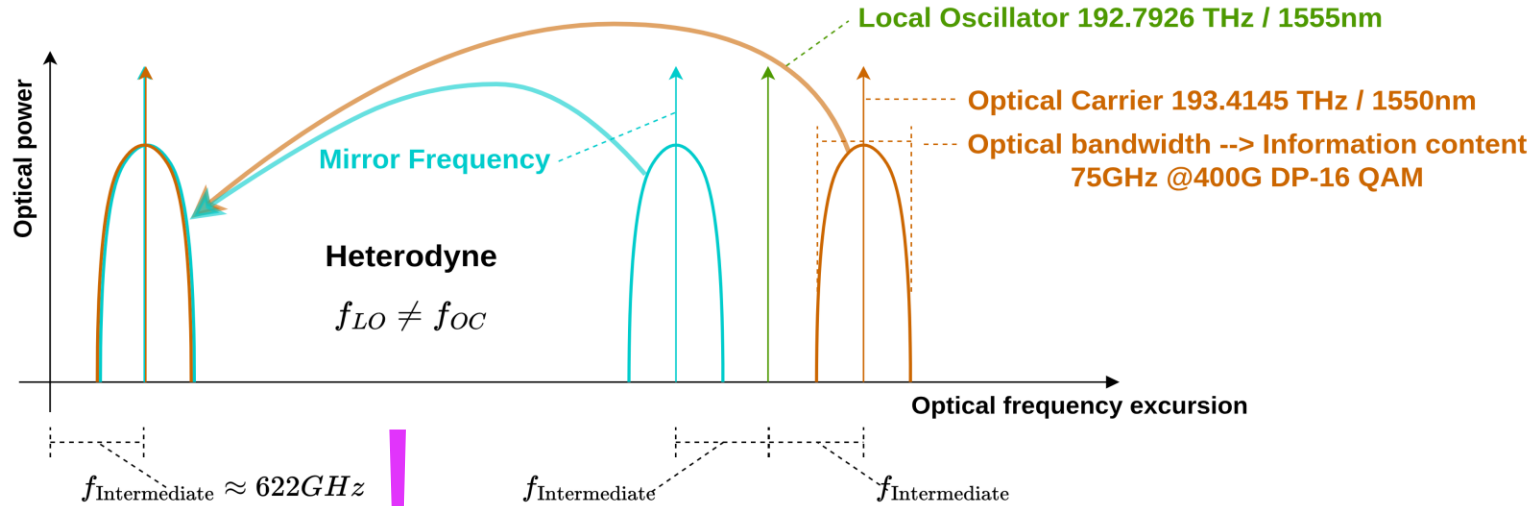

Homodyne

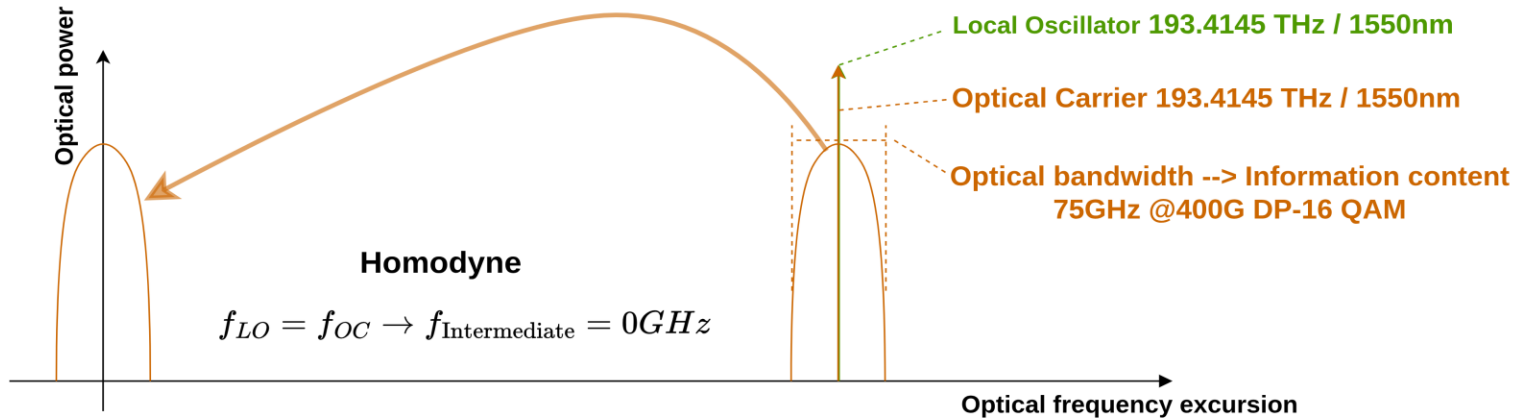

# Intradynne Detection

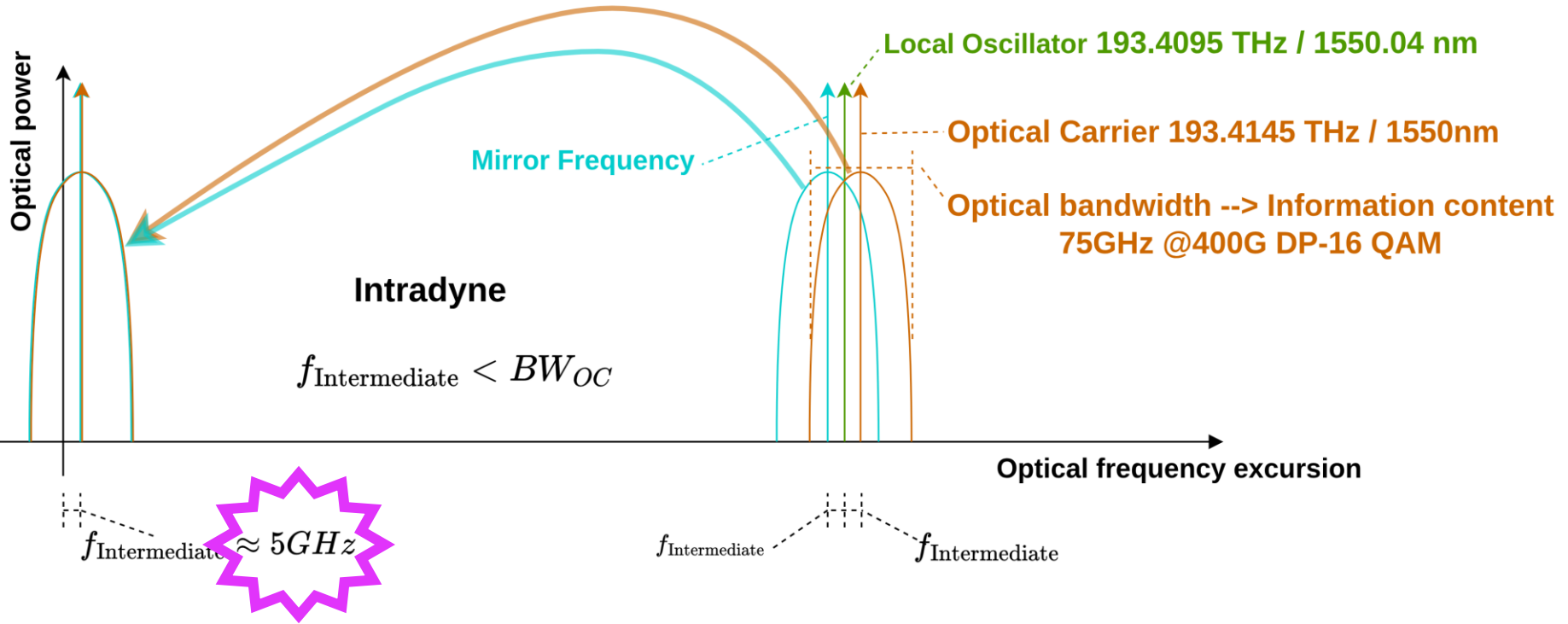

# we made it

to the moon



# Coherent Detection DIY-Superchannels

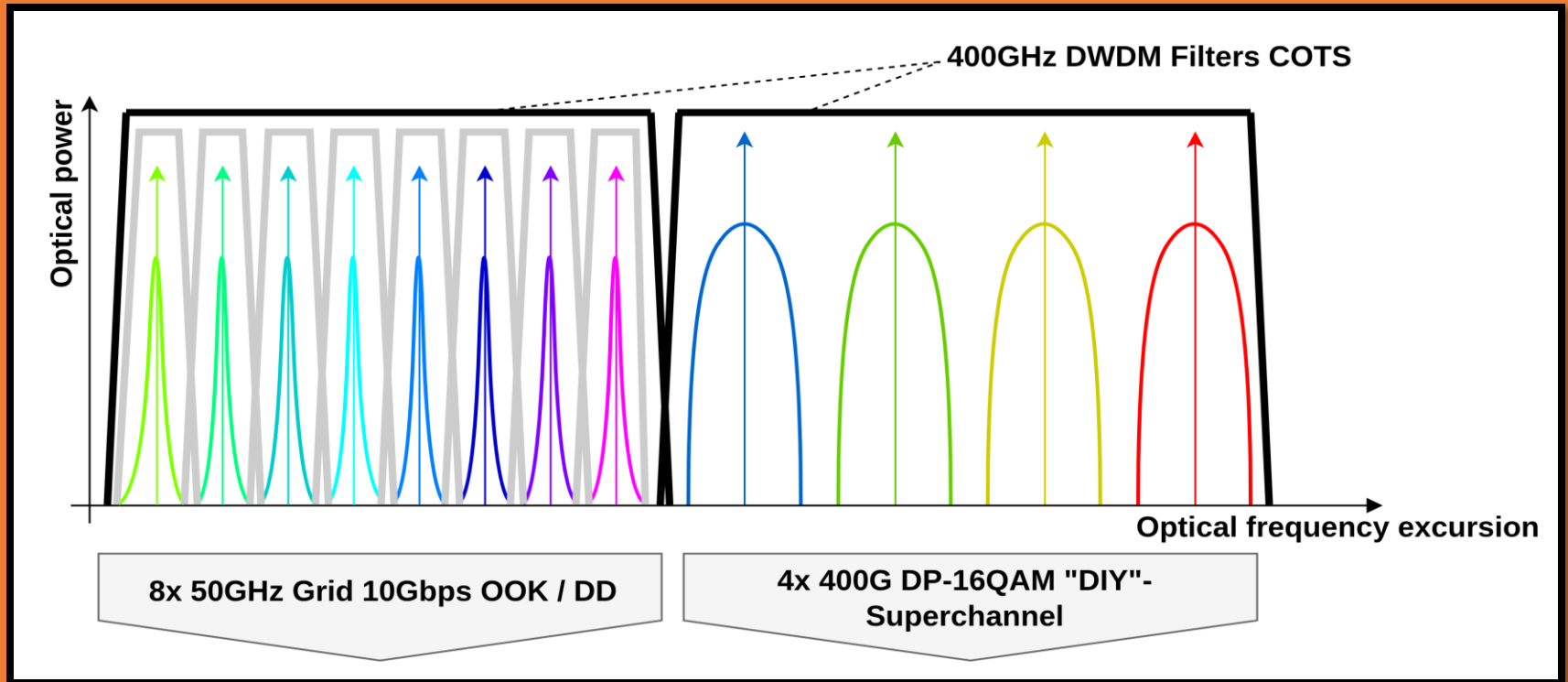

Run the subband through  
regular 50GHz DWDM  
MUX / DeMUX

Use low-cost PLC 1x4 /  
4x1 splitters to combine  
TX and split RX

Note: Blake Willis  
achieved optimum  
performance @  
100GHz spacing

# Flexible Network Architecture

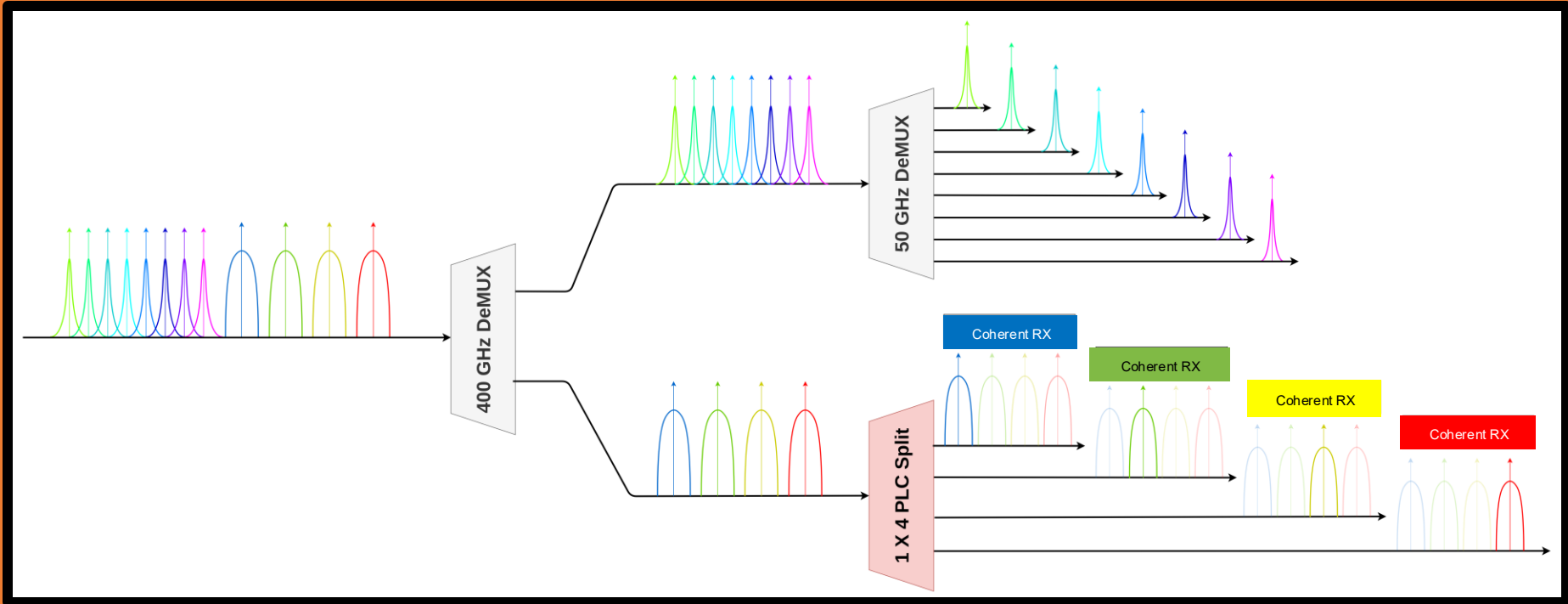

**hint: make a frequency plan for your spans**

# our way to the universe

400GHz MUXes will make your network flexible

Foundation for Colorless are Balanced-receiver

Think in **THz** and **GHz**  
not in nm or channel numbers

800G Coherent ZR+  
DD and OSFP is available



**300GHz ADTRAN FSP 3000 IP OLS**



**12.8T**  
liquid cooled XPO is approaching

# MY CONCLUSION

I can't wait for tonight's social!

SFO

source: <https://www.google.com/maps/>  
date: 05/20/26

**FLEXOPTIX Inc.**

Suite 417, 433 Airport Blvd.,  
CA 94010

one more thing





# Coherent BIDI

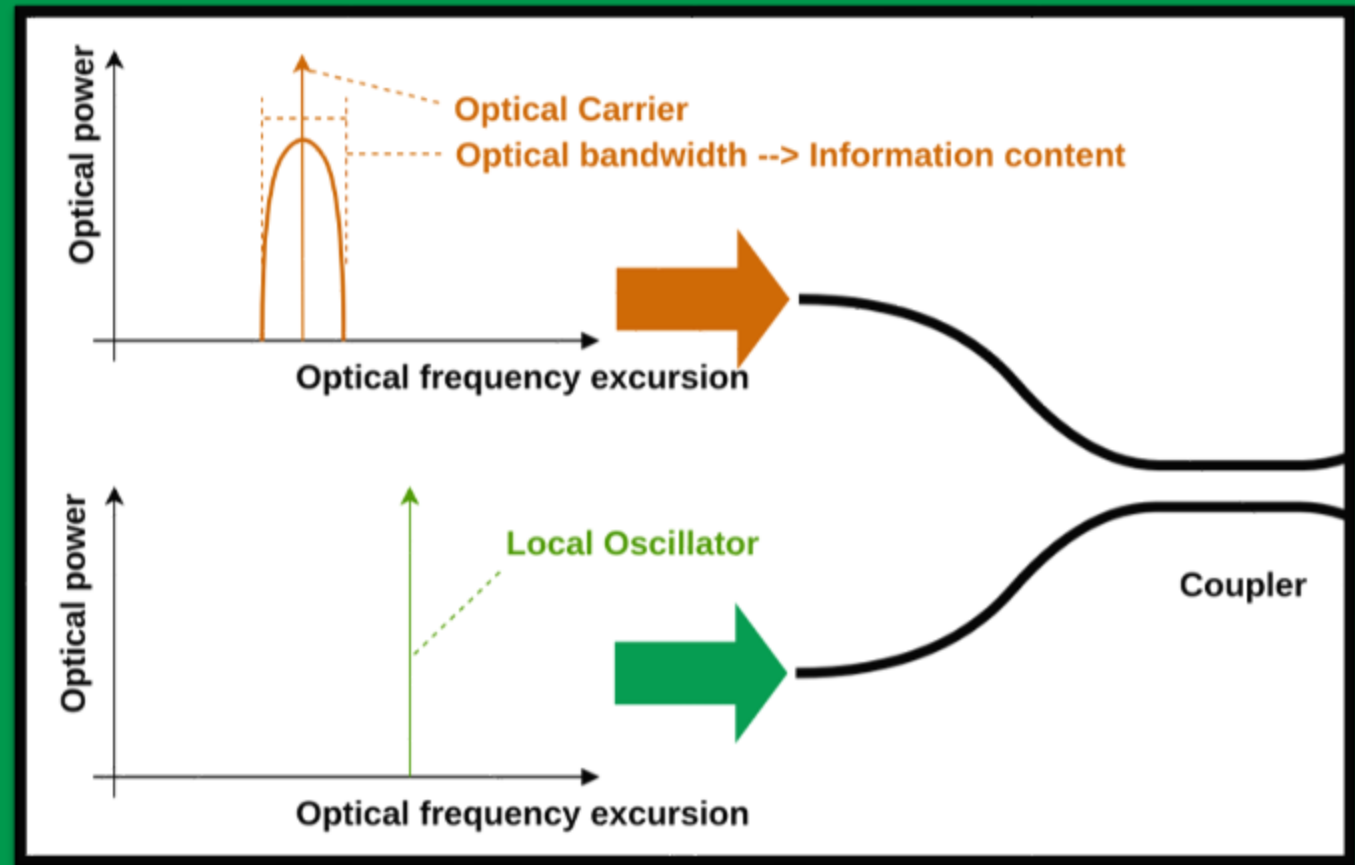

requires a 2nd laser source for RX Local Oscillator

Authors:

[Thomas.Weible@flexoptix.net](mailto:Thomas.Weible@flexoptix.net)

[Gert.Matyasowicz@flexoptix.net](mailto:Gert.Matyasowicz@flexoptix.net)

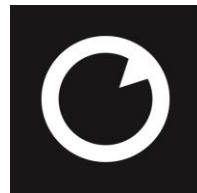

**FLEXOPTIX**